

3000-5000 W

MECHANICAL PARAMETERS

MECHANICAL PARAMETERS

Nr.	Parameter	VALUE	Units	Notes	Picture
1	Motor model	QS-205 3000W / V3 / H50 / 48-96V			
2	Motor type	3 phase Outer Rotor BLDC / PMSM hub motor			
3	Axle Configuration	Single Shaft			
4	Motor diameter	222	mm		
5	PCD	4*114.3	mm	Other PCD on request: 4*98; 5*118	
6	CB	58	mm	Other on request	
7	Brake system	Disc Brake		PCD 3*80mm, M8	
8					
9	Speed (depends on wheel size)		km/h	Optional 40-70 km/h	
10	Matched Wheel	13 inch		Suitable RIMS: 13 inch or above	
11					
12	Color	Black	-		
13	N.W. // G.W.		kg		
14	Package	34*34*33	cm ³	Carton	

DRAWING:

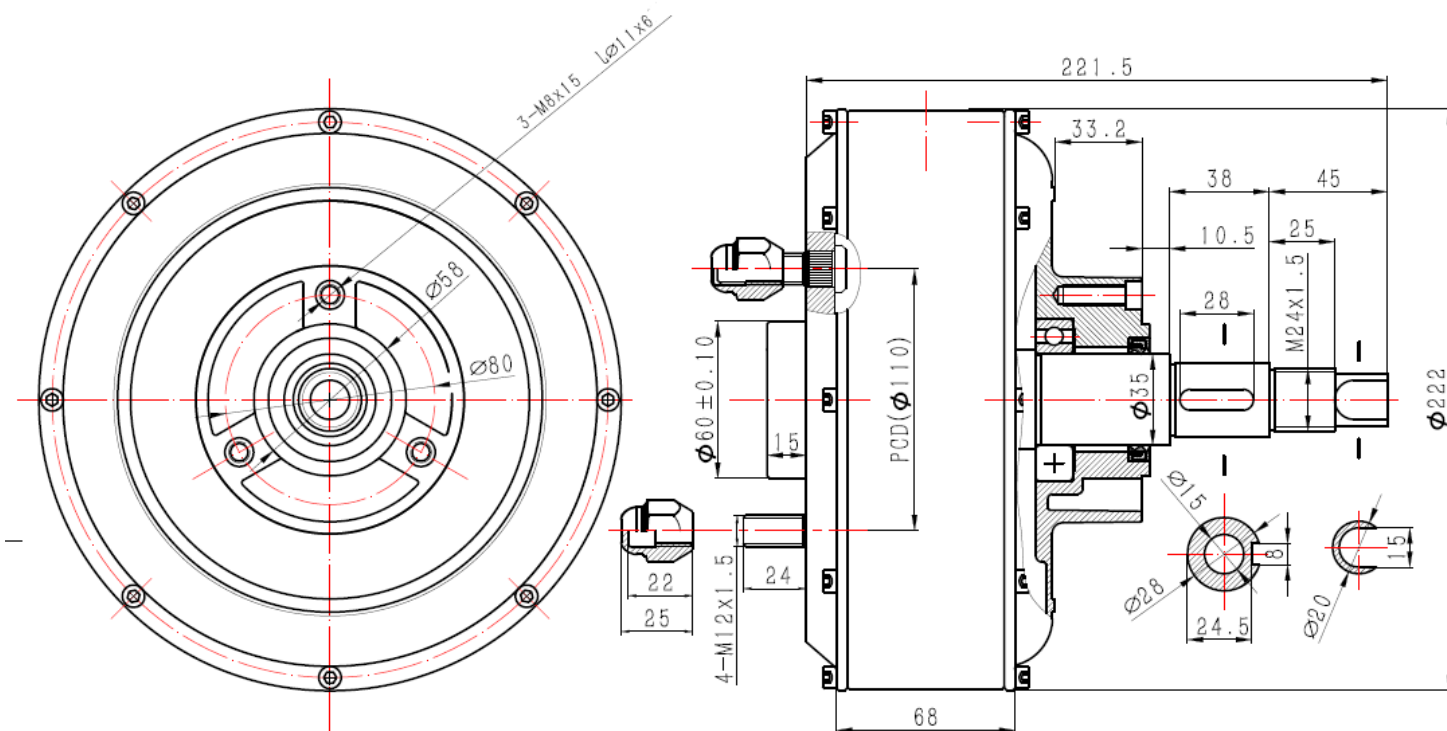

MOTOR SPECIFICATION:

Nr.	Basic parameters	Value	Units	Notes	Picture
1	Rated Power [kW]	3	kW		
2	Max Power [kW]	5	kW	Peak 20 kW in few sec	
3	Rated Voltage [V]	48	V	Optional 48-96V	
4	Rated Current [A]	67	A		
5	Peak Input Current [A]	104	A		
6	Max Phase Current [A]	350	A	In short time	
7	Max Current duration time [s]	10	Sec.		
8					
9	Number of Pole pairs	16	Pairs	32pcs.	
10	Magnet Height	50	mm		
11	Max RPM	933	RPM	Depending on kV	
12	kV (RPM per Volt)	13.0	RPM/V	Optional kV: 6.0 / 9.0 / 13.0 / 14.9 / 18.0 / 19.4 etc.	
13	Rated torque [N.m]	68	N.m.		
14	Max Torque [N.m]	189	N.m.		
15	Max Efficiency [%]	86-92	%		
16					
17	Phase Resistance [mΩ]		mΩ	Depending on Windings	
18	Phase Induction [100 kHz]		uH	Depending on Windings	
19					
20	Hall sensors	2	Set.	One for spare, Waterproof connector	
21	Hall sensor electrical Angle	120	°		
22	Hall working Voltage	5	V		
23	Temperature sensor	KTY83/122		Other type on request	
24	Recommended working temperature	up to 70	°C	Peak 120°C; * 1 NOTE	
25					
26	Waerproof Grade	54	IP		
27	Cooling type	AIR		Natural AIR cooling	
28	Cross Section of Phase Wire	10	mm ²	not include insulation layer)	

1 NOTE: Suggestion (Setting of Controller)

When it's 90 °C inside of motor (in 30s), the current should be limited 50%.

When it's 120 °C, the controller shut down. When it drop down to 70°C, the controller work again.

QS-205 MOTOR TEST CURVE [30x4T]

Description	U [V]	I [A]	P1 [W]	M [N.m]	n [RPM]	P2 [W]	EFF [%]
No Load	72.30	3.520	254.5	0.1	853.9	10.01	3.9
Max Eff	71.51	80.27	5 740	68.1	738.5	5 271	91.8
Max P out	70.51	80.27	5 740	68.1	738.5	5 271	91.8
Max Torque	70.30	77.08	5 497	189.2	46.9	929.3	16.9
End	70.30	77.08	5 497	189.2	46.9	929.3	16.9

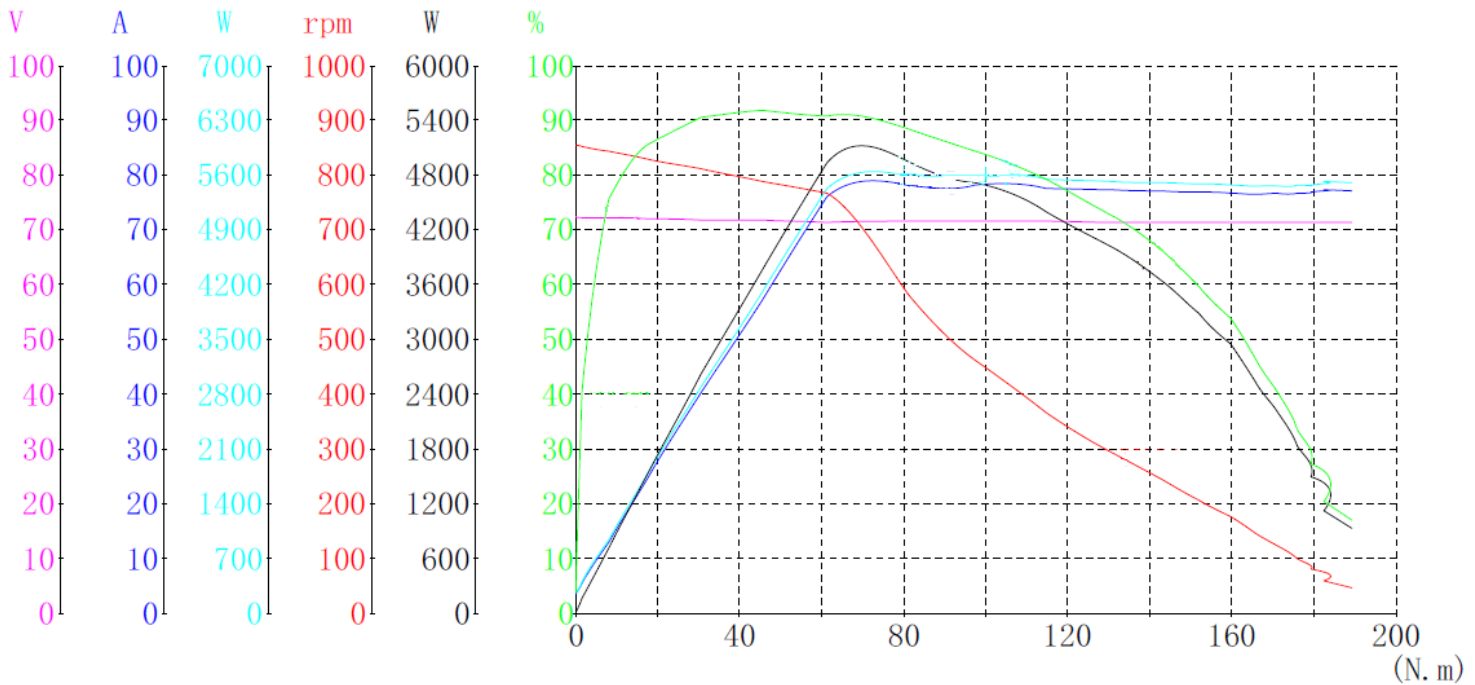

Please note that the test curves can be done at different currents & Voltages. Therefore the torque and RPM can be different. However at respectively currents the torque at 72V and 96V will be the same or very similar.

The test curves at different motor windings and controller settings will be different. These curves only for general information.

Regarding Motor Supply Voltage / RPM and Power.

For example if motor is with windings 72V, this motor can also be run at lower voltages, such as 48V. The difference is that you wouldn't get as much power output since a lower voltage is associated a lower max attainable rpm. As power (W or Nm/s) is the product of angular speed (1/seconds) and torque (nm), with the same amount of torque and a lower rpm, you would have a lower power output.

You can achieve the same amount of torque at any voltage as torque is directly dependent on current. You may see something called a torque constant, such as Nm/A or ft-lbs/A. Simply multiply by the current, and you'll get the torque output before accounting for mechanical and electrical losses.

The main limiting factor on the amount of current you can pump into a motor is heat, which can melt the insulating varnish if too high.

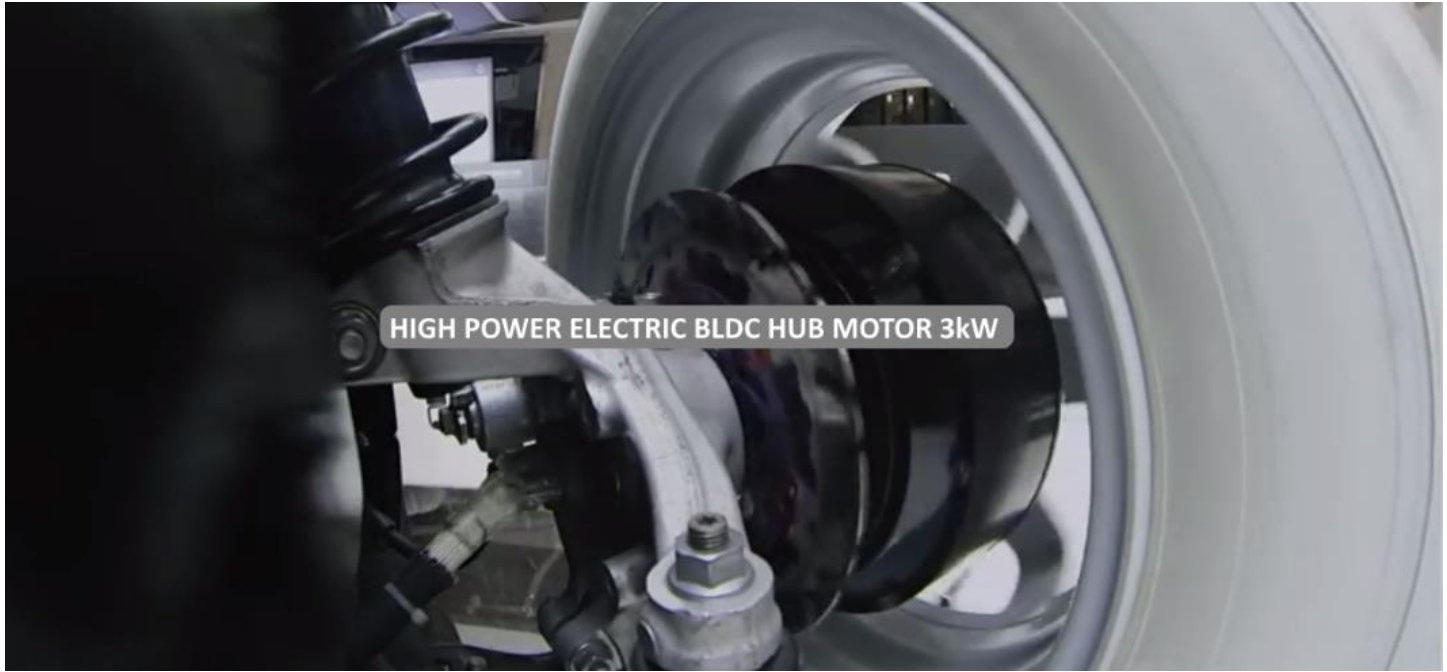

8kW (273 type motor) vs 3kW (205 type motor)



CONVERSION KIT

